

DOCK LEVELERS

Dock Leveler Systems for all Applications

SUPERIOR QUALITY & FEATURES

Whether it's for new construction or retro-fit applications, Rol-Lift offers a superior solution to your dock leveler needs.

Rol-Lift designed its **Dock Levelers** to maintain structural integrity, product longevity, and require minimal maintenance.

TILT SYSTEM

- Rol-Lift Dock Levelers are designed to tilt to either side - up to 4" - when loaded this floating action reduces deck fatigue and allows full width contact between the lip and truck bed
- Prevents damage to forks, tires, steering system and load, thereby prolongs life of dock leveler bed
- Standard on Rol-Lift Hydraulic and Mechanical Dock Levelers

DECK SUPPORT

- Continuous single-piece headboard increases the strength across the of the front of the deck

LIP HINGE

- Lip hinge is a full width design to maximize strength and to withstand the dynamic forces
- Minimum of 7 rear hinge support blocks plus two corner mounted tilt pockets for a total of 9 rear hinge supports

FALL SAFE SYSTEMS

- Limits platform free fall
- Velocity fuses for hydraulic models and mechanical fall-safe legs for mechanical models

MAINTENANCE STRUT

- Built-in safety strut is designed to protect maintenance and service personnel while unit is in the extended position

TOE PROTECTION

- Full range toe guards are made of heavy gauge steel plate and come standard in ANSI approved safety yellow
- The stationary section is fully welded to both the outside channel and the headboard for added structural strength
- High visibility safety striping alerts personnel when dock leveler is in the extended position above cross traffic

DOCK PROTECTION

- Standard laminated bumpers (2 each) plus mechanical night locks and stops

Hydraulic DOCK LEVELERS



Mechanical DOCK LEVELERS



I-Beam Series

DOCK LEVELERS

Deck support is provided by a minimum 6 I-beams welded at dynamic impact points. At higher capacities that increases to 8 I-beams. I-beams offer greater strength support.

'RLH' & 'RLE' Models: 30,000 lb to 80,000 lb Rated Capacities

These models are high performance systems. Push-button electro-hydraulic operation. Automatically actuated hydraulic beveled lip. Maintenance-free hydraulics. Rol-Lift offers a range of safety features such as full range toe guard protection, hydraulic fall safe protection and the capability to be inter-locked with our optional hydraulic truck restraint system with driver safety communications package.

- Hydraulic lip cylinders increase operating efficiency, reduce maintenance requirements over mechanically actuated lips.
- Velocity fuse fall safe limits free fall to within 3".
- Continuous duty rated hydraulic power system with 1 HP fan cooled (TEFC) motor available for all electrical requirements. UL/CSA approved electrical components.
- Mechanical stops and night locks are standard.
- RLE model comes with rugged wall-mounted remote control station with shielded push buttons for DOCK OPERATION and RESET. Watertight to NEMA4 standards.
- RLH model comes with a multi push-button control station which allows the operator to select automated or manual control functions. Independent deck and lip operation with standard automatic return to stored position. Dust tight & drip proof to NEMA12 standards.

'RLM' Model: 30,000 lb to 50,000 lb Rated Capacities

Rol-Lift Model RLM Mechanical Dock Levelers offer excellent value. To operate, pull the release chain. Rol-Lift's heavy duty lift springs do the work. The deck rises and the lip is smoothly powered out to the locked position. Simply walk the deck down onto the truck bed and begin loading. On truck departure, the lip automatically releases and lowers allowing the unit to be returned to the cross traffic position.

- Heavy duty main lift springs with lifetime warranty.
- Dependable friction type hold down system that reduces cross traffic bounce and provides instant hold at any point in the full operating range.
- Patented lip actuator. As deck rises, the lip smoothly powers out to the locked position. Releases automatically when truck departs.
- Yieldable lip safely collapses if struck while in extended position.
- Mechanical fall safe prevents platform free fall.
- Mechanical stops and night locks are standard.

Box Beam Series

DOCK LEVELERS

Solid formed tensile steel channels are welded to the underside of the deck at the dynamic impact points to prevent "dishing" and provide structural integrity.

'RLHC' Model: 25,000 lb, 30,000 lb & 35,000 lb Rated Capacities

Easy to operate hydraulic system incorporates single pushbutton control for both the deck and the lip. Controls are conveniently located on one remote wall-mounted push button station and the leveler is powered by a self-contained maintenance-free power pack.

- Rugged wall-mounted remote control station has shielded push buttons for DOCK OPERATION and RESET. Watertight to NEMA4 standards.
- Hydraulic deck and lip cylinders increase operating efficiency.
- Hydraulic system includes a 1 HP fan-cooled (TEFC) motor. Totally enclosed and equipped with overload protection. Hydraulic circuit design requires no maintenance. UL/CSA approved.
- Mechanical stops and night locks are standard.
- Velocity fuse fall safe limits free fall to within 3".
- The deck cylinder is mounted against the headboard and the deck. This superior design means the full length of the deck is supported in the event a truck departs while the Dock Leveler is in use.

'RLMC' Model: 25,000 lb, 30,000 lb & 35,000 lb Rated Capacities

Easy to operate - no heavy lifting. Simply pull the release chain. The deck is driven up by heavy duty lift springs and the lip is smoothly powered out to the locked position. Dock is then "walked" down onto the truck bed. When the truck departs, the lip releases, allowing the unit to be returned to the cross traffic position.

- Rol-Lift features a friction type hold down system - instant hold at any point in the full operating cycle.
- Main axle is mounted on sealed bearing for trouble-free operation.
- As deck rises, the lip smoothly powers out to the locked position. Releases automatically when truck departs.
- Cam roller fitted with sealed ball bearings to assure smooth, continuous cycling.
- Mechanical fall safe. Prevents platform free fall.
- Positive lip-lock with automatic release.
- Heavy duty main lift springs with lifetime warranty.
- Pivot points incorporate pre-lubricated bushings.
- Lip safely collapses if struck while in extended position.
- Mechanical stops and night locks are standard.

RLVS Series

VERTICAL STORING DOCK LEVELER

The Rol-Lift **RLVS Series Dock Leveler** saves you time and money. It is designed for climate controlled applications where the overhead door must be kept closed when not in use. The dock is stored in the vertical position behind the overhead door allowing for a complete, energy efficient seal. Heating and cooling loss is minimized.

The **RLVS Series** includes a “controlled lowering” hydraulic system - the dock attendant must push and hold a button to lower unit. The power pack also includes “hydraulic float” to allow deck to move up and down during load transfers. With a service range of 12” above cross traffic and 6” below, the **RLVS Series** from Rol-Lift can efficiently service a wide range of trailers. The open style continuous pit design is easier to form and reduces construction costs. It also simplifies cleaning and maintenance.



FEATURES

- 30,000 lb capacity
- Full length I-beam deck support
- 16” long checker lip
- Independently controlled hydraulic deck and lip cylinders
- Remote 1 HP power pack
- 10” cast-in-place rear anchor channel
- Maintenance stand
- 3” run-off guards
- (2) bumpers

OPTIONS

- Longer lips
- Higher capacities
- Arctic oil
- Bumper risers

- Solid steel checkered lip controlled by double-acting cylinder
- One piece headboard and full width piano style hinge provides unsurpassed strength to the lip and hinge area
- 3” high run-off guards are standard
- Mechanical lock for added security when unit is in stored position
- NEMA12 rated push button control
- Individual buttons for up, lip, down and reset functions
- Constant pressure style down button ensures controlled lowering during operation
- Wide flange 6” x 4” structural I-beams reinforce the checker deck
- 1 HP power pack includes TEFC motor with overload protection
- Inverted deck cylinder and power pack connection reduces maintenance by eliminating hydraulic hose flex-

MODEL	DOCK LEVELER DIMENSIONS				PIT DIMENSIONS		
	DECK WIDTH	DECK LENGTH (with lip)	LIP EXTENSION	CAPACITIES	PIT WIDTH	PIT LENGTH	PIT DEPTH (plus 1/2” slope)
RL605VS	72”	60”	16”	30,000 lb and 35,000 lb	continuous	45.5”	10.5”
RL606VS	72”	72”				57.5”	
RL705VS	83”	60”				45.5”	
RL706VS	83”	72”				57.5”	

Edge-of-Dock Leveler

HYDRAULIC & MECHANICAL

The **Edge-of-Dock Leveler** from Rol-Lift is ideally suited for applications where standard size trucks are serviced. The **Edge-of-Dock Leveler** is mounted on the face of the dock wall providing a safe and self-storing dock.

STANDARD DESIGN FEATURES

- 20,000 lb (9,091 kg) to 30,000 lb (16,636 kg) capacities
- 66" (1,676 mm) to 78" (1,981 mm) wide
- Deck and lip plates made of premium grade 50,000 psi minimum yield safety checker plate steel
- Working range of 5" (127 mm) above or below dock level
- One piece, continuous front and rear hinge pins
- Hole in lip allows for quick and easy handling by installers
- Heavy-duty back frame - 3/8" (10 mm) thick x 6" (152 mm) high
- Each unit supplied with two rugged bumper blocks that can be lagged or welded to the dock face
- 10" (254 mm) wide x 13" (330 mm) high x 4" (102 mm) thick reinforced molded rubber bumpers are standard

OPTIONS

- Installation hardware kit
- Approach ramp
- Face plate (existing)
- Pour-in curb angle (new construction)

MODEL	DECK SIZE (with lip extended) width x length	MODEL	DECK SIZE (with lip extended) width x length	CAPACITY
RLMXE6620	66" x 27"	RLHE6620	66" x 28"	20,000 lb
RLMXE7220	72" x 27"	RLHE7220	72" x 28"	20,000 lb
RLMXE7820	78" x 27"	RLHE7820	78" x 28"	20,000 lb
RLMXE8320	83" x 27"	-	-	20,000 lb
RLMXE6625	66" x 27"	RLHE6625	66" x 28"	25,000 lb
RLMXE7225	72" x 27"	RLHE7225	72" x 28"	25,000 lb
RLMXE7825	78" x 27"	RLHE7825	78" x 28"	25,000 lb
RLMXE8325	83" x 27"	-	-	25,000 lb
RLMXE6630	66" x 27"	RLHE6630	66" x 28"	30,000 lb
RLMXE7230	72" x 27"	RLHE7230	72" x 28"	30,000 lb
RLMXE7830	78" x 27"	RLHE7830	78" x 28"	30,000 lb
RLMXE7830	83" x 27"	-	-	30,000 lb

RLHE: HYDRAULIC MODEL

- Side-to-side tilt provides 2-3/4" (70 mm) of tilt to compensate for canted trucks, assures a smooth transition surface into and out of trucks and also reduces structural fatigue of the leveler
- Rear hinge is supported in 8 places - 6 double hinge lugs plus 2 corner tilt pockets
- 1/2 HP tenv power unit and single push button control
- 16" (406 mm) long lip
- Optional 18" (457 mm) long lip

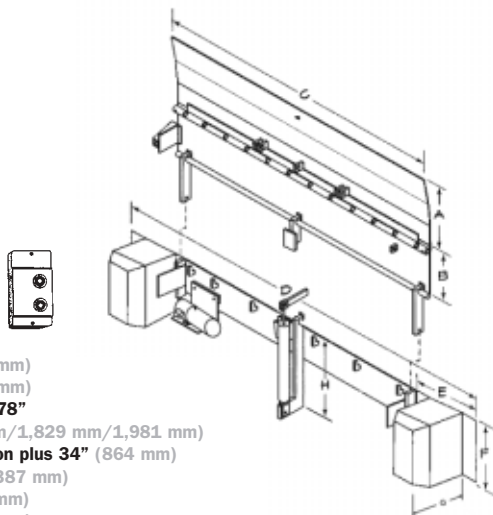

- A - 16" (406 mm)
- B - 11" (279 mm)
- C - 66"/72"/78"
(1,676 mm/1,829 mm/1,981 mm)
- D - C dimension plus 34" (864 mm)
- E - 15 1/4" (387 mm)
- F - 13" (330 mm)
- G - 15" (381 mm)
- H - 25" (635 mm)

Note: Some components not illustrated

RLMXE: MECHANICAL MODEL

- Balanced spring-assisted deck lifting system
- Fixed rear hinge
- One piece, continuous front and rear hinge pins
- 83" (2,108 mm) wide model available
- 15" (381 mm) long lip

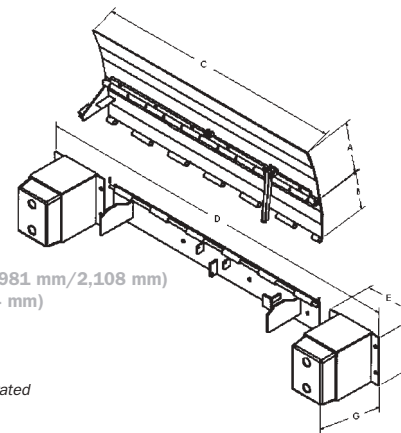

- A - 15" (381 mm)
- B - 11" (279 mm)
- C - 66"/72"/78"/83"
(1,676 mm/1,829 mm/1,981 mm/2,108 mm)
- D - C dimension plus 34" (864 mm)
- E - 15 1/4" (387 mm)
- F - 13" (330 mm)
- G - 14" (355 mm)

Note: Some components not illustrated

Options & Accessories

LOADING DOCK PRODUCTS

DOCK SEALS & SHELTERS

- Rol-Lift door seals, canopies and rigid truck shelters are designed for any door opening
- Create an air tight seal that blocks out inclement weather, insects, dust and may reduce pilferage
- Save money on energy costs



DOCK LEVELER CONVERSION KITS

- Rol-Lift hydraulic conversion kit upgrades mechanical dock levelers to high performance, easy to use hydraulic dock levelers for increased longevity, productivity and employee safety
- Proven hydraulic operation plus reduced moving parts reduces downtime and maintenance costs
- Universal design can be retrofitted on most competitive models
- Best suited for growing, high volume companies that require the advantages of a hydraulic dock leveler without incurring the cost of replacing a complete mechanical dock leveler



BUMPERS, WHEEL CHOCKS & DOCK LIGHTS

- Rol-Lift accessories are designed for the loading dock area to protect dock equipment, building wall, product and personnel
- Dock bumpers available in molded or laminated rubber to reduce building damage
- Vertical and horizontal bumper extensions and bumper plates available to suit any application
- Wheel chocks are the most economical way to prevent trucks from unscheduled departures
- Dock lights help increase safety by providing soft bright light to illuminate trailer interiors

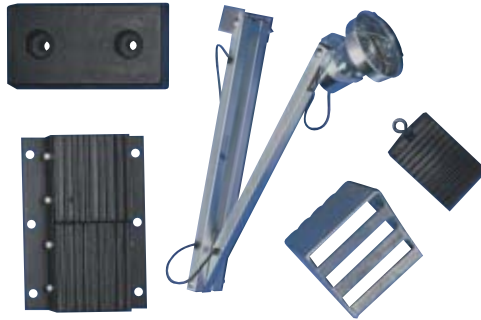

NEW CONSTRUCTION PIT KITS

- Available as part of the original dock leveler or advance shipped (*bottom pan not included*) to facilitate pit construction



FREE STANDING FRAME

- When space limitations do not permit construction of a pit, an option is a dock leveler with its own free standing frame
- Custom sizes available

BRUSH OR RUBBER WEATHER SEALS

- Prevents debris from entering dock leveler mechanism
- Reduces heating and cooling loss

NOTE: Certain equipment and features illustrated or described in this brochure are optional at extra cost. Some equipment and features may not be available for all models. In keeping with its policy of continuous product improvement Rol-Lift reserves the right to discontinue or change specifications, models and equipment without notice or obligation.

Authorized
Distributor

www.rol-lift.com

DOCKS 09/15/02-0

tel **866-889-8766** fax **866-882-8998**

85 Heart Lake Road South • Brampton, ON Canada L6W 3K2
tel 905-457-3815 fax 905-457-2313